

ROTATOR GR 46

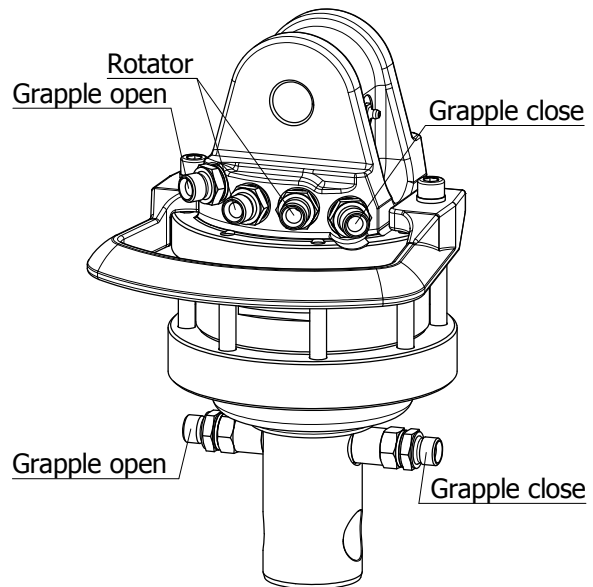
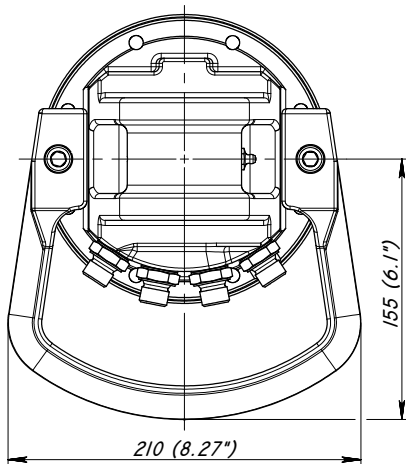
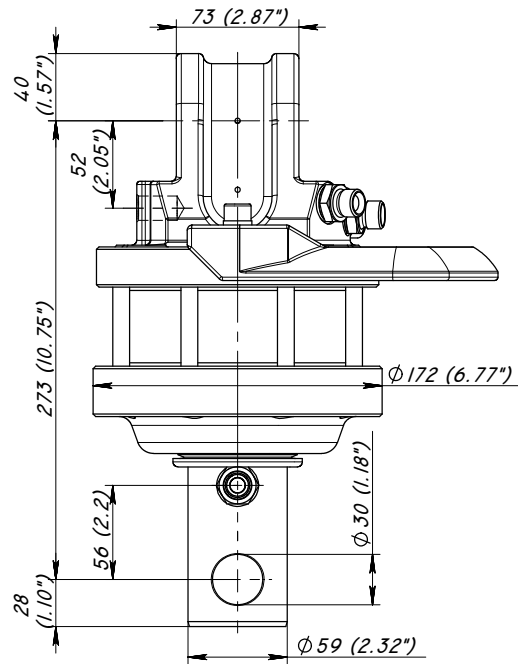
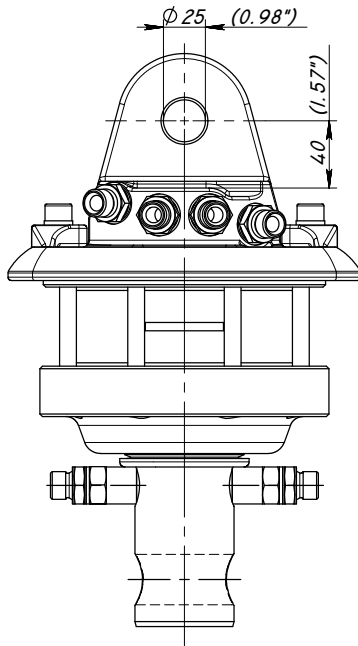

Technical data

Rotation	Unlimited
Max axial load static, KN (lbf)	45 (10118)
Max axial load dynamic, KN (lbf)	25 (5621)
Torque at 25MPa (3625psi), Nm (lb ft)	1000 (737)
Rec oilflow, l/min (US gallon)	20 (5.3)
Weight, kg (lb)	23 (51)

Max working pressure:

Rotator	↔R↔	Max 25 MPa (3625 psi)
Grapple / Tool open	↔G↔	Max 20 MPa (2900 psi)
Grapple / Tool close	→G←	Max 30 MPa (4350 psi)

Connection:

G 3/8"
G 3/8"
G 3/8"

2005.09.30.



BALTROTORS



SIT RIGHT RKN AB

ROTATOR GR 46

List of parts

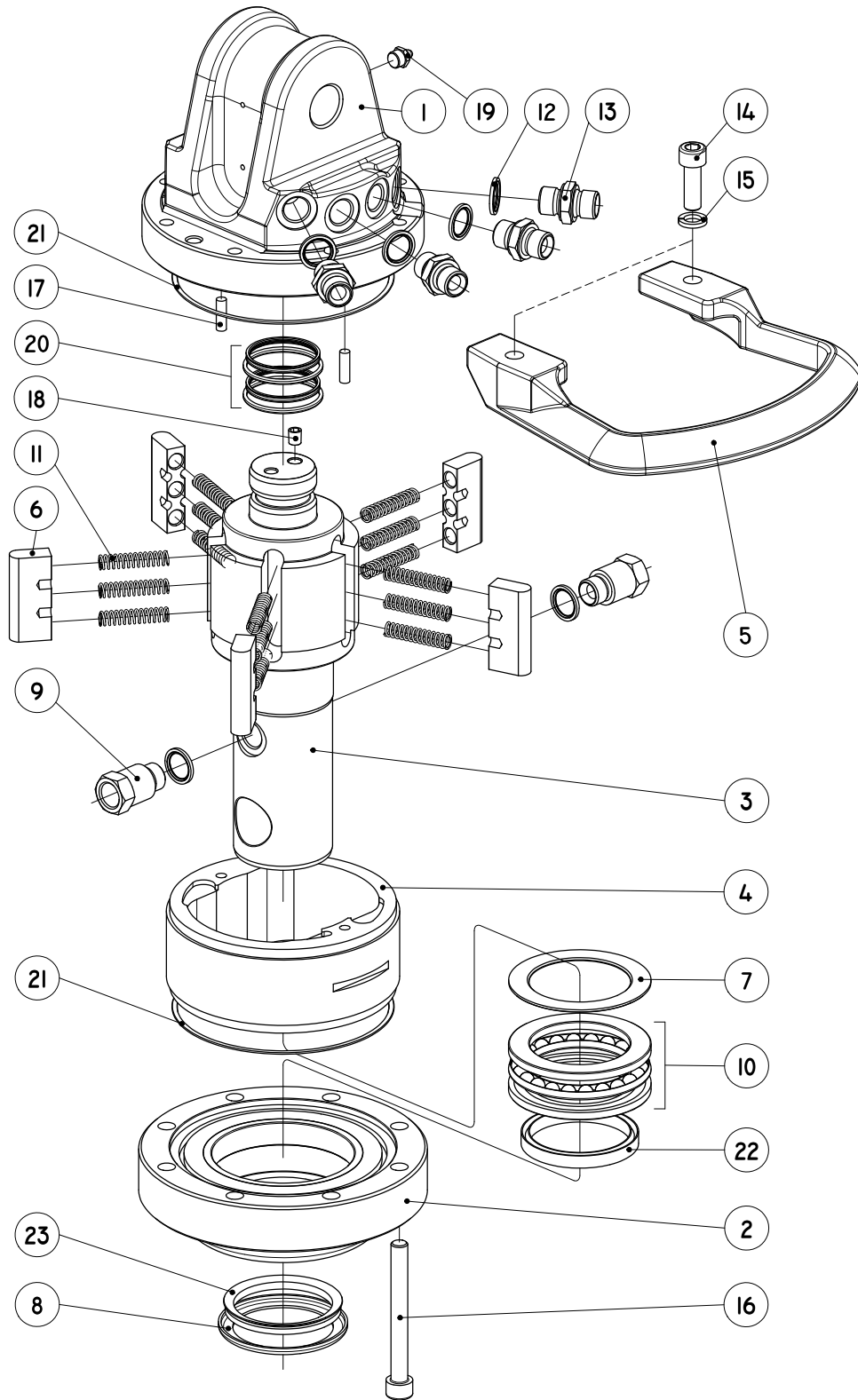

2005.09.30.

ROTATOR GR 46

List of parts

Pos.	Part	Title	Quantity	Notes
1	MTR 46.01 LA	Stator plate, upper	1	
2	MTR 46.02 B	Stator plate, lower	1	
3	MTR 46.006	Rotator shaft	1	
4	MTR 46.007	Stator frame	1	
5	MTR 46.03 LA	Hose guard	1	
6	MTR 46.008	Vane	5	
7	MTR 45.011	Shim	1	
8	MTR 45.010	Washer	1	
9	MT 0205	Nipple	2	
10	51112	Axial bearing	1	
11	MTR 100.009	Spring	15	
12	GB - 6 Tredo	Bonded seal	6	
13	0101-6	Nipple	4	
14	MC6S 12.9 M10x30	Screw	2	
15	DIN 127 B ø10	Spring washer	2	
16	MC6S 12.9 M10x90	Screw	8	
17	6 m 6x20	Pin	2	
18	835-02	Tap	1	
19	1.2.C6	Grease nipple	1	
20	GHH/R 40/47.5x3.2	Glide ring	2	
21	OR 126.00x2.50	O - ring	2	
22	TS 60/70x8	Seal	1	
23	VA - 60	V - seal	1	

2005.09.30.



BALTROTORS



SIT RIGHT RKN AB